

# Study of Transients using Wavelet Transform

P. Hariramakrishnan<sup>1</sup>, S. Sendilkumar<sup>2</sup>

<sup>1</sup>Research scholar, Sathyabama University, Chennai, Tamilnadu, India,  
<sup>1</sup>harirmk@gmail.com

<sup>2</sup>Professor, Electrical and Electronics Engineering Dept,  
Panimalar Engineering College, Chennai, Tamilnadu, India,  
<sup>2</sup>sendilkumar2009@gmail.com

**Abstract**— This paper presents the study of power system transients using wavelet transform. Transients due to energization of capacitor banks and due to fault has been taken for consideration. The wavelet transform generates wavelet coefficients for the generated transients. Using Parseval's theorem, energy and standard deviation are retrieved for transients. The wavelet transform is used to produce instantaneous frequency vectors of the signals, and then the energies of these vectors, obtained using Parseval's theorem, are utilized for the classification of different transients. The advantage of the proposed algorithm is its ability to distinguish different transients based on frequency change. The performance of this algorithm is bought bespeak by simulation of different events using MATLAB & SIMULINK software. The test results show that the new algorithm is very fast and accurate in identifying events.

**Keyword**:- Transients due to fault, Oscillatory transients, Wavelet transform and Parseval's theorem.

## I. INTRODUCTION

Transients in power systems are temporary over voltages or over currents of short duration that lasts from few nano seconds to few milliseconds. The duration for which transients lasts is very insignificant when compared to the total operating time of the power system. But they cause immediate and most severe danger to sensitive electrical and electronic equipments, fire in some buildings, blackout in a city and shutdown of a plant, etc. Almost 80% of transients are internally generated like normal switching on or off of equipments, heating and ventilation systems, etc. Every industrial machine on power system practically causes transients or is adversely affected by transients. For better understanding the nature of the transient, they have to be sampled at a higher sampling rate because they are very fast and short duration waves [1].

In literature, there are several signal processing techniques like Fourier Transform (FT), Short-Time Fourier Transform (STFT), S-Transform, wavelet transform (WT) and wavelet packet transform (WPT) are used for examining the transients. Fourier Transform and Short-Time Fourier Transform can be used only for a fixed window width which is inadequate for the analysis of the transient non-stationary signals [2]. In modern spectrum and harmonic analysis, Discrete Fourier Transform (DFT) is used to monitor and assess the recorded data. Transient signal tracking using DFT is not successful, because of its fixed length window. The DFT method gives magnitude and phase angle of different frequency components of a periodic and stationary voltage or current waveform. Rectangular sampling windows of 10 cycles width in 50Hz power system is used and grouping of output bins of DFT analysis is done to compute the voltage and current waveform harmonic distortion. However DFT analysis only provides information in the frequency domain with a resolution that depends on the width of the time window. It doesn't give any time information about the signal provided [3].

The wavelet transform approach can be used for analyzing the power system transients. Wavelets are nothing but short oscillatory waveforms with zero mean and fast decays to zero amplitude, especially suited duration to analysis of non-stationary signals. Unlike Discrete Fourier Transform analysis, the wavelets simultaneously evaluate a signal in both time and frequency domain with different resolutions [4]. Wavelets are used in transient analysis when it is not important to know the exact frequency of a disturbance, but the time information is important [5]. Discrete Wavelet Transform (DWT), the digital representation of the continuous wavelet transform (CWT), can be implemented with the wavelet function as low-pass filter (LP) and its dual high-pass filter (HP). This decomposition tree is down sampled by two at the output of the low-pass and high-pass filters which scales the wavelet by two for the next stage [6].

## II. INTRODUCTION TO WAVELET TRANSFORM

In both the STFT and the FT, the same window is used for the analysis of the entire signal. In the late 1970s J. Morlet came up with the wavelet in analyzing high frequency components with short time spans and low frequency components with long time spans, in different frequencies. The wavelet is a short duration waveform with a zero average value. Here the shortness refers to a finite length window function, i.e, compactly supported. Here the wave is meant for the oscillatory function only. The CWT is defined as given in equation 1 where  $\tau$  is the translation parameter's and  $\psi(t)$  is the transforming function known as the mother wavelet.

$$CWT_x^\psi(\tau, s) = \Psi_x^\psi(\tau, s) = \frac{1}{\sqrt{|s|}} \int x(t) \Psi^*\left(\frac{t-\tau}{s}\right) \cdot dt \quad (1)$$

The term mother implies that the function with different regions of support that are used in the transformation process, are derived from one main function, or the mother wavelet. The mother wavelet is a prototype for generating all the other window functions. In wavelet transform, the resemblance index i.e. the wavelet coefficient between the mother wavelet and the signal under consideration is calculated [7]. A multistage filter bank is used to decompose the signal in to various levels using the LP filter and the HP filter as shown in Fig 1. The LP filter will result in approximation coefficients of the original signal, and the HP filter in detailed coefficients of the signal.

### A. Reasons for Using the Wavelet Transform

The FFT, which is a tool for high speed implementations of the FT uses sines and cosines as basic functions, which are non-local, and stretch out to infinity. They do a very poor job in detecting transients, and cannot provide the time localization of the frequency components in a signal. The wavelet transform has some advantages when compared to the FT. Wavelets have compact support, which means that wherever the function is not defined it will have a value of zero. It helps in speeding up the computations and also tells us about the locality of the wavelet in the time domain.

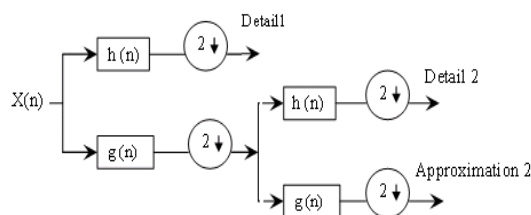

Fig. 1. Implementation of the discrete wavelet transform

### B. Selection of mother wavelets

The selection of the mother wavelet plays a significant role in the time frequency analysis. These have to be carefully selected to better approximate and capture the transient spikes of the faulty signal. The mother wavelet will not only determine how well we estimate the original signal, but also affect the frequency spectrum of the fault signal. The Haar wavelet is the simplest wavelet in the wavelet family. It was the first wavelet introduced, and is rarely used in practice, because it is discontinuous and lacks energy compaction. The Daubechies wavelet is one of the more advanced wavelets that was povered by several researchers. While the Haar does not allow for sharp transitions and fast attenuation, the Daubechies wavelets have continuous derivatives that respond well to discontinue. The Daubechies wavelets have a better frequency property than the Haar wavelets. When Haar is used to decompose the signal, the wavelets cannot efficiently separate the signal into low frequency and high frequency bands. The Daubechies wavelets allow the user to decide how fluctuation is acceptable in the high frequency bands.

## III.METHODOLOGY OF THE PROPOSED WORK

- The methodology of the proposed work is shown in Fig. 2.
- The transients due to energization of capacitor and due to fault are simulated using the MATLAB/SIMULINK software.
- The wavelet transform is applied on the simulated transients.
- The features extracted from WT are then processed to obtain the energy values using Parseval's theorem.
- The transient events are then classified according to the energy value they contained.

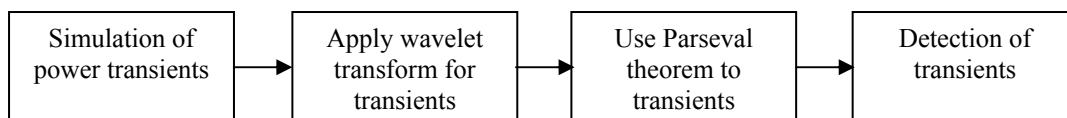

Fig. 2. Methodology of the proposed work

#### IV. APPLICATION OF PARSEVAL’S THEOREM AND FEATURE EXTRACTION

The energy of signals that go through discrete wavelet transform decomposition can be described by

$$\frac{1}{N} \sum_T |X(t)|^2 = \frac{1}{N_j} \sum_h |cA_{j,h}|^2 + \sum_{j=1}^J \left( \frac{1}{N_j} \sum_h |cD_{j,h}|^2 \right) \quad (2)$$

Where N is the sampling period. The first term on the right of above equation denotes the average power of the approximated version and the second term is for detailed version, whereas the left term represents the total energy. In the present study, the energy distributions for different transient events are divided in to one level for the approximate version and five for the detailed version. The coefficient cA of approximate version and coefficient cD of the detailed version are used to extract the features of signals [8].

#### V. INTRODUCTION TO TRANSIENTS

Transients are momentary changes in voltage or current that occur over a short period of time. Usually its duration is described as approximately 1/16<sup>th</sup> of a voltage cycle or about 1ms. Transients are divided into three categories: impulsive transient, oscillatory transient and transient due to fault. When 77% of the peak-to-peak voltage of the pure component is of one polarity, the transient is then classified into the impulse category. A sudden, non- power frequency change in the steady state condition of voltage, current or both that includes positive and negative polarity values is an oscillatory transient. The transient due to fault is caused by fault conditions, the energization of large loads which require high starting currents or intermittent loose connections in power wiring. The transients are classified into any of these categories related to the frequencies they contained. Each type of transient can be associated with a group of phenomena occurring on the power system. The two types of transients are depicted in the following Fig. 3.a and 3.b. The capacitor switching oscillatory transients is considered here.

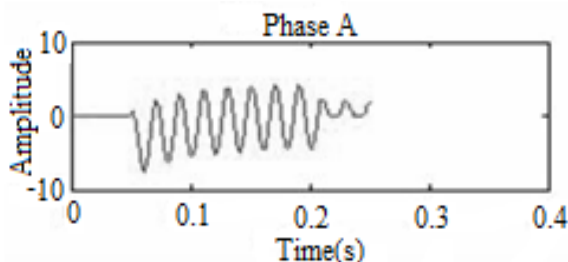

Fig. 3a. Transient due to switching

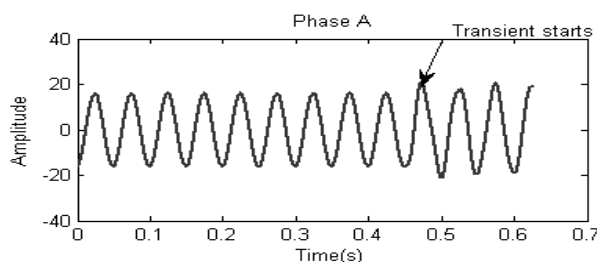

Fig. 3b. Transient due to fault

### VI. SIMULATION RESULTS

The transients due to capacitor switching and due to fault on the system have been taken for consideration for the analysis.

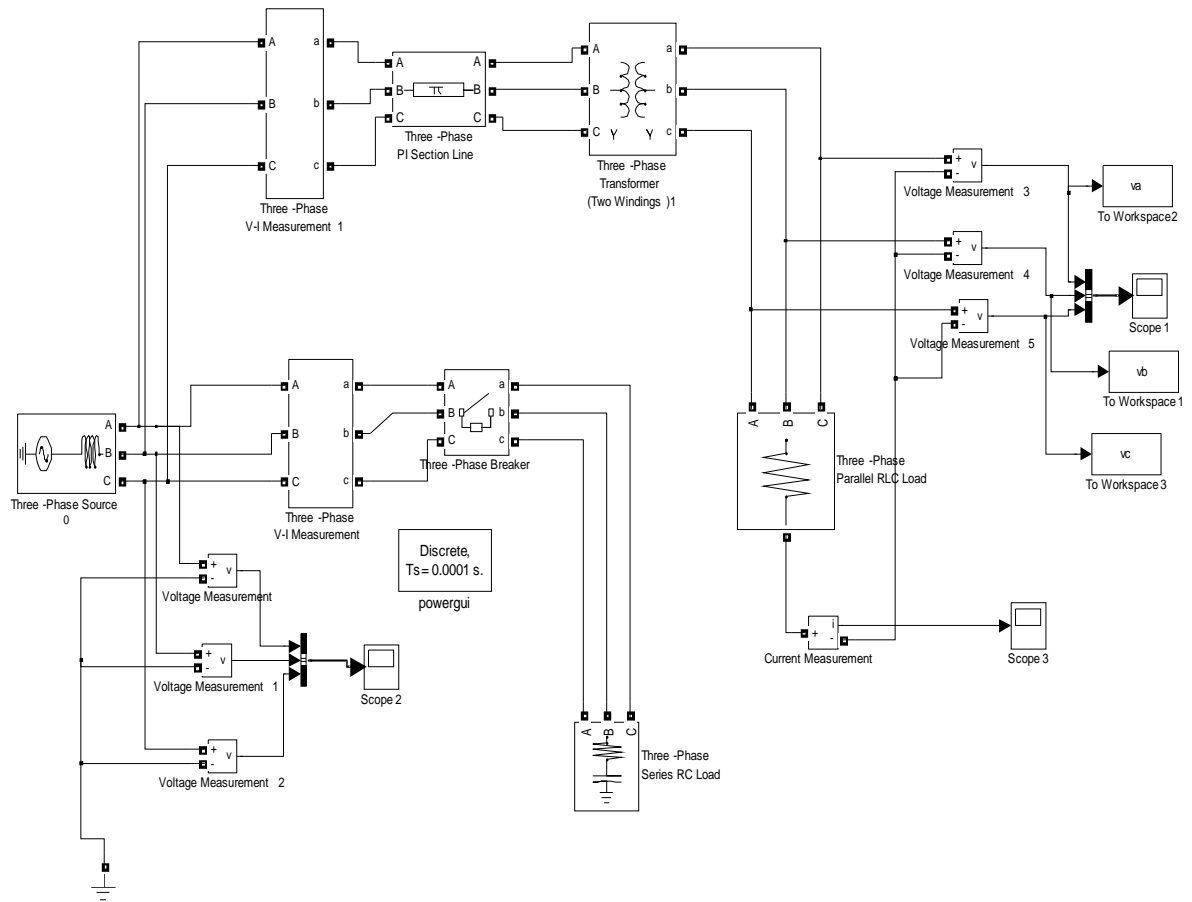

Fig. 4. Power System Model for Transients

#### Case.1 Transient due to capacitor switching

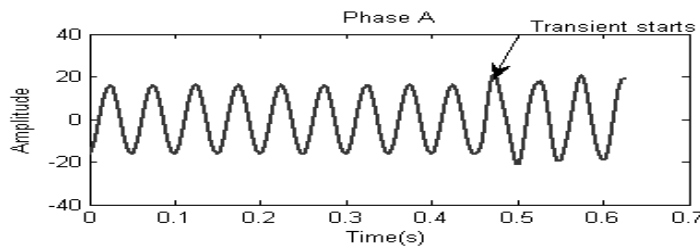

Fig. 5a. Generation of Transients due to Capacitor Switching

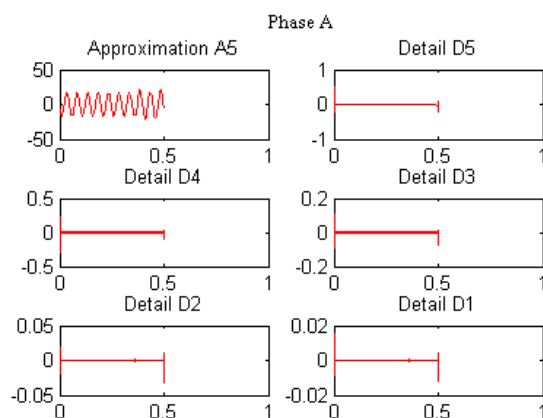

Fig. 5b Amplitudes of Wavelet Co-efficient for Capacitor Switching

Case 2 Transient due to fault on the system

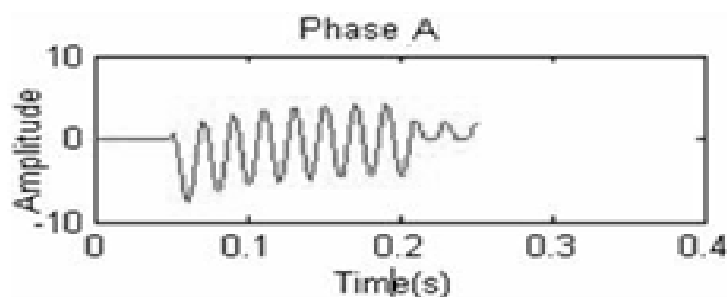

Fig. 6a. Generation of Transients due to Fault

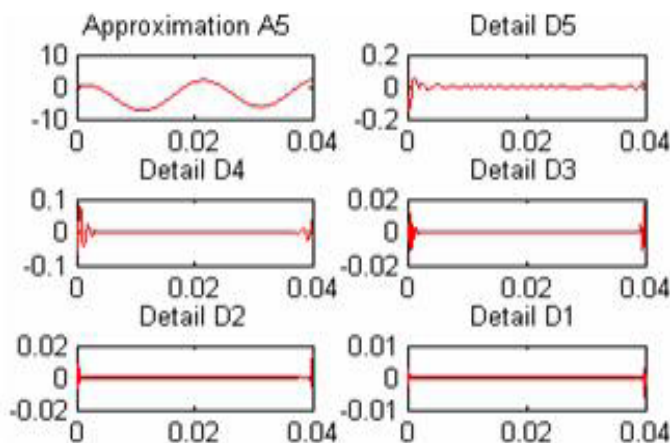

Fig. 6b. Amplitudes of Wavelet Co-efficient due to Fault

Fig. 4 is used for the simulation of transients. Fig. 5a and Fig. 6a shows the generation of transients and Fig. 5b and Fig. 6b shows the amplitude of WT. Occurrence of transients due to energization of capacitance connected at the secondary of the transformer and due to fault are captured. Oscillatory phase voltages due to transients are obtained by voltage moment of the load side. The transient voltages shown in Fig. 5a and 6a processed to WT produce wavelet coefficients as shown in Fig. 5b and Fig. 6b respectively using Daubachies mother wavelet. Using Parseval's theorem, energy and STD are calculated for the duration of transients and they are tabulated in Table 1. These calculated energy of transients can be discriminated for different events of occurrence.

Table.1 Energy and STD values of transients

|  | <b>ENERGY (10<sup>8</sup>)</b> | <b>STANDARD DEVIATION(10<sup>3</sup>)</b> |
|--|--------------------------------|---|
| Oscillatory Transient due to capacitor switching | Phase A 0.0000058977           | Phase A 0.0021933                         |
|  | Phase B 0.0000060083           | Phase B 0.0022525                         |
|  | Phase C 0.0000059933           | Phase C 0.0022268                         |
| Transient due to fault                           | Phase A 0.000086594            | Phase A 0.0007840                         |
|  | Phase B 0.000055451            | Phase B 0.0005103                         |
|  | Phase C 0.000054621            | Phase C 0.0005811                         |

## VI CONCLUSION

In this paper, two common types of transients such as transient due to fault and energization of capacitor are examined using wavelet transform. These transients that made distortion in alternating voltage waveform are analysed by using the energy values produced by Parseval's theorem. The obtained values of energy and standard deviation of transients are different for fault and switching conditions. The transients are classified from each other based on a threshold value set for each type of transient. Simulation has been performed on a sample power system model to demonstrate the effectiveness of the proposed approach for transient waveform classification. The proposed method is the reduction of data size as well indicating the main characteristics of signal without losing its distinguishing characteristics.

## REFERENCES

- [1] Martin Valtierra-Rodriguez, Rene de Jesus Romero-Troncoso, Roque Alfredo Osornio-Rios and Arturo Garcia-Perez, "Detection and Classification of Single and Combined Power Quality Disturbances Using Neural Networks", IEEE Industrial Electronics, Vol. 61(5), pp. 2473 – 2482, May 2014.
- [2] P. Ramesh Babu, P. K. Dash, S. K. Swain, and S. Sivanagaraju, "A new fast discrete S-transform and decision tree for the classification and monitoring of power quality disturbance waveforms", Intl. Trans Electr Energy Sytems, Volume 24(9), pp. 1279-1300, September 2014.
- [3] Om Prakash Mahela, Abdul Gafoor Shaik and Neeraj Gupta, "A critical review of detection and classification of power quality events", Renewable and Sustainable Energy Reviews, Vol. 41, pp. 495-505, January 2015.
- [4] Ruqiang Yan, Robert X. Gao and Xuefeng Chen, "Wavelets for fault diagnosis of rotary machines: A review with applications", Signal Processin, Vol. 96, pp. 1-15, March 2014.
- [5] Lei Ye, Dahai You, Xianggen Yin, Ke Wang, and Junchun Wu, "An improved fault-location method for distribution system using wavelets and support vector regression", International Journal of Electrical Power & Energy Systems, Vol. 55, pp. 467-472, February 2014.
- [6] D. P. Mishra, "Sag, Swell and Interruption Detection Using Wavelet in LabVIEW", International Journal of Computer and Electrical Engineering, Vol. 5(4), pp. 387, August 2013.
- [7] Y. Zhang, T. Y. Ji, M. S. Li and Q. H. Wu, "Identification of Power Disturbances Using Generalized Morphological Open-Closing and Close-Opening Undecimated Wavelet", IEEE Transactions on Industrial Electronics, Vol. 63(4), pp. 2330 – 2339, April 2016.
- [8] Sendilkumar.S, Mathur.B.L, Joseph Henry, "Differential Protection for Power Transformer Using Wavelet Transform and PNN, International journal of electrical and electronics Engineering, Volume 4,issue 7,2010,pp.468-474.