

Design and Development of Labview Based Steering Wheel Angle Sensor System

Tony George¹, Susan Zacharia², Elizabeth Rufus³ and Zachariah C Alex⁴

^{1,3,4} School of Electronics Engineering, Vellore Institute of Technology
Vellore, Tamil Nadu, India

² Computer Science Department, Vedavyasa Institute of Technology
Malappuram, Kerala, India

¹ tonygeorge@vit.ac.in

⁴ zachariahcalex@vit.ac.in

Abstract—Conventional angle sensors can measure only 360°, but passenger car steering wheel turns through +/-720° (a total of 4 complete turns). In this paper we describe iGMR based steering wheel angle sensor implementation which can be used as a rotation sensor to measure +/- 720°.

Keyword- Steering Wheel Angle Sensor, IGMR, Angle Sensor, GMR.

I. INTRODUCTION

The discovery of Power Steering (PS) system and its implementation in automobiles has substantially reduced the driving effort by assisting in turning the wheels with the help of an external power source. In a modern Electrical Power Steering (EPS) an electronic motor is directly connected to the steering gearbox that helps in turning the steering wheel with less effort and ease. Steering wheel angle sensor is used to detect the orientation and motion of the steering wheel of a vehicle. This measured angle is used to give assistive power to steering via an electric motor and according to the driving conditions it changes the amount of assistance [1]. The steering wheel angle is also used for electronic stability program, advanced front lighting systems, lane departure warning system and 4 wheel steering etc. There are different methods to find out the angle of a steering wheel based on Optical encoder, Hall Effect and AMR.

Optical encoder steering wheel angle sensor for measuring four turn (1440) requires a counter or register because it can measure only 360° at a time and in next rotation its angle value is added to the last value using rotation register. This method has several disadvantages while using in automobile because quiescent current requires storing steering angle data that can't give at certain situations [3].

Hall-effect steering wheel angle sensor is another method in which Hall Effect vane switches is used to register the angle and the number of rotation of steering wheel. A magnetic code disc rotates with the steering shaft and strongly reduces the magnet's field or screens it off completely. Absolute measurement with good resolution is not achieved in this method [3].

Anisotropic magneto resistive (AMR) sensors can be used for measurement of steering wheel angle but sensitivity of the sensor is less compared to Giant Magnetic Resistance (GMR) based angle measurement sensors.

The integrated Giant Magnetic Resistance (iGMR) TLE5010 manufactured from infineon is a 360° angle sensor is used in this work, which measure the angular movement with the orientation of a magnetic field of a permanent magnet fixed to the rotating object by calculating the sine and cosine angle elements with monolithic iGMR [4]. Passenger car steering wheel turns through +/-720° (a total of 4 complete turns), conventional angle of rotation sensors can measure only 360°. So we need to measure +/- 720 degree using an angle rotation sensor with contact less, absolute angle measurement, without the need of a revolution counter but should give angle information upon "wake up".

II. EXPERIMENTAL SETUP FOR INTEGRATED GIANT MAGNETIC RESISTANCE BASED MULTI TURNS ABSOLUTE ANGLE SENSOR SYSTEM

Four turns absolute angular position sensor system requires special mechanical arrangement to rotate the magnets over the magnetic angle sensors. In this system sensor as shown in Fig 1 (a) is used for measuring four turns of steering angle so that a hub gear wheel G attached to steering column rotate two cogwheels g_1 and g_2 with different number of teeth. These cogwheels are used as measuring gear wheels which is fixed with a permanent magnet at center. Each cog wheel with magnet fixed at center is place over iGMR angle sensor. The number of teeth on one cog wheel differs to that on other, which means that they therefore change their rotational angle values. By combining the angle measured using these two sensors it is possible to obtain the total angle of rotation. This increase the measurement ranges to +/-720 degree, which allows four turns absolute angular position sensing of steering wheel.

The two measuring gears g_1 and g_2 representing angle θ_1 having n number of teeth and angle θ_2 having $n+3$ number of teeth are twirled by a hub gear Z representing angle ϕ having $n+9$ teeth of the steering column. The arrangement of a steering wheel angle sensor is shown in Fig 1 (a). The direction of the magnetic field of the magnet centered cogwheel determines the angle θ_1 and θ_2 using $iGMR_1$ and $iGMR_2$ angle sensors. The $iGMR_1$ and $iGMR_2$ elements are fixed to steering shaft cover. The measuring gears g_1 and g_2 have magnets attached with the gears. These magnets intern is twirled when the hub wheel G turns . A change in magnetic field is detected by $iGMR_1$ and $iGMR_2$ and that magnetic field changes angle value. By combining the angle values of $iGMR_1$ and $iGMR_2$ the total angular rotation is calculated.

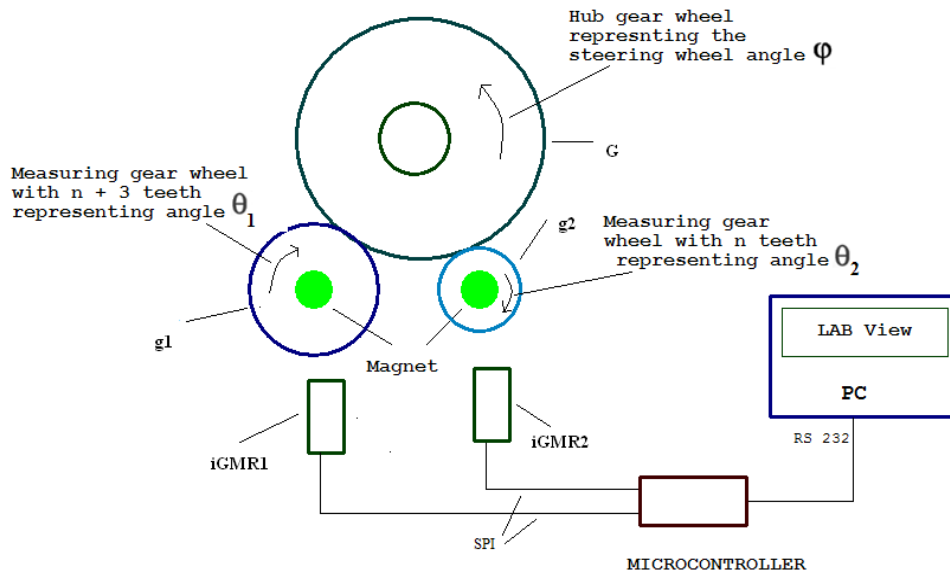

Fig 1. (a) Arrangement of a steering wheel angle sensor



Fig 1. (b) Experimental setup for four circles absolute angular position sensor system ent of a steering wheel angle sensor

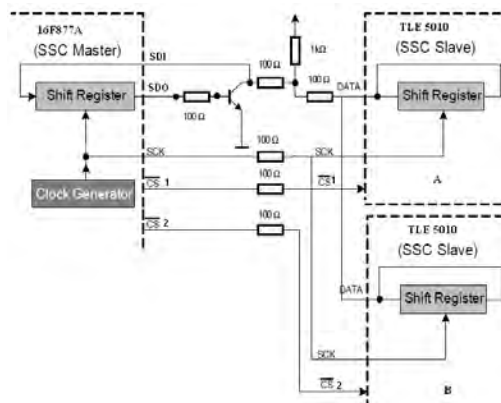

Fig 1. (c) Connection diagram of microcontroller with both iGMR sensors

III. DETERMINATION OF THE STEERING ANGLE FROM THE ANGLES OF MEASURING GEARS

The mathematical relations for the steering wheel angle are obtained from the pair of measuring gears angles. The angle of rotation ϕ of the steering wheel with hub gear Z is calculated from the measured angle θ_i of the iGMR_i sensor gear wheel as follows [2]:

$$\phi = \frac{Z_i}{Z} (\theta_i + n_i \times \Omega) \quad (1)$$

where Z is the number of teeth of the driving gear wheel (steering column), Z_i the number of teeth of sensor gear wheel i , n_i the current number of revolutions of the sensor gear wheel i . A pair of sensors with $i=1$ and $i=2$ are necessary to compute the number of revolutions n_i . For sensor elements Ω , Ω_1 and Ω_2 (where $\Omega = \Omega_1 = \Omega_2 = 360^\circ$) and numbers of teeth of the measuring gear wheels z_1 and z_2 . In this case we have the numbers of periods as p_1 and p_2 , where $p_2 = z_1$ and $p_1 = z_2$. The following equations are valid in a similar way for arbitrary Ω and numbers of teeth. The computation of the angle of rotation ϕ is unique in the range $[0, \phi_{\max}]$. The maximum angle of rotation ϕ_{\max} for two sensor elements is

$$\phi_{\max} = \frac{1}{Z} \times p_1 \times p_2 \times \Omega \quad (2)$$

From equation (1) and $p_1 = Z_2$ and $p_2 = Z_1$ we get

$$\phi = \frac{p_2}{Z} (\theta_1 + n_1 \times \Omega) = \frac{p_1}{Z} (\theta_2 + n_2 \times \Omega) \quad (3)$$

$$p_1 \times \theta_2 - p_2 \times \theta_1 = (p_2 \times n_1 - p_1 \times n_2) \Omega \quad (4)$$

$$\frac{p_1 \times \theta_2 - p_2 \times \theta_1}{\Omega} = p_2 \times n_1 - p_1 \times n_2 \quad (5)$$

The right hand side is replaced with an integer k ,

$$k = p_1 \times \frac{\theta_2}{\Omega} - p_2 \times \frac{\theta_1}{\Omega} \quad (6)$$

Here p_1 , p_2 , Ω are constant then

$$k = \theta_2 - \theta_1 \quad (7)$$

The k value calculated from angles θ_1 and θ_2 is an integer as per equation (7) is rounded to the next value. We need to solve equation (7) using θ_1 and θ_2 and select the corresponding number of revolutions n_1 or n_2 from lookup table [2]. From the values n_1 or n_2 , the rotation angle ϕ is obtained. A setup is made as shown in Fig 1(b) for experimental analysis of four circles absolute angular position sensor system designed. Tested the output verified the results for 1440° by rotating 4 turns in this setup and found suitable to be fixed on the steering.

IV. IMPLEMENTATION OF DATA ACQUISITION SYSTEM FOR ANGLE SENSOR

For communication with iGMR, angle calculation and to send this data communication to different locations to display or store the result, we need to develop a system which needs proper hardware and software. For display and store the result in Personal Computer (PC) a data acquisition system is developed with LabView and RS232 communication. Microchip PIC Microcontroller (PIC16F877A) serial peripheral interface (SPI) is used to get angle data from the iGMR (TLE5010). Angle calculations are done in the microcontroller and the result is transmitted to PC LabVIEW program using RS232 communication with microcontroller.

A. Hardware For Data Acquisition System

A 360° angle sensor, TLE5010 is used to detect the changing direction of the magnetic field of a magnet placed in the measuring cogwheels. iGMR sensors have two resistance bridges. These sensors arranged in a way that makes them 90 degrees to each other. The bridge parts are composed of GMR (giant magneto resistance) elements. When the steering wheel is turned, a measurement cogwheel with permanent magnet rotates over a GMR element and this changes the bridge voltage. An integrated analog to digital converter (ADC) is used to convert the two bridge voltage to 16 bit digital value and is stored in separate registers. The registers contain sine and cosine angle components which are converted to angle value mathematically with trigonometric functions. PIC16F877A microcontroller is used for this mathematical operation. Data communication between TLE5010 ADC register and PIC16F877A is done via bi-directional SPI interface. The read out from sine and cosine values registers are mathematically processed for finding the changing direction (angle) of the magnetic field.

For measuring larger steering angles two TLE5010 is used. Both are connected to one SPI interface of a PIC16F877A as shown in Fig 1 (c). Each connected TLE5010 is addressed using a dedicated chip select .The broadcast command is used for communication between the microcontroller and TLE5010 . The clock for the sensors is provided by an external from a boxed crystal oscillator which ensures a synchronous operation. The sensor has its own PLL to generate the necessary clock frequency for the chip operation [4]. The read out data from both the TLE5010 is converted into angle values of each sensor using an arc tan function. These two angle values are transmitted to PC and is processed in LabVIEW to convert it into steering wheel angle and save the data in PC. A line driver MAX232 is used to connect PIC16F877A with PC serial port.

B. Software for Data Acquisition System

CCS C compiler is used to program low cost PIC16F877A microcontroller. Microcontroller works as a data acquisition card for LabVIEW program that runs on PC. TLE5010 is connected to microcontroller SPI interface. Built-in function for SPI is used with some modification according to TLE5010 datasheet. PIC16F877A reads the iGMR analog voltage data from register of TLE5010 and convert into angle value using mathematical function. This angle values from both sensor is send to the PC using RS232 communication protocol. In LabVIEW program these two angle values are converted into steering wheel angle.

V. DETERMINATION OF FOUR TURNS ABSOLUTE ANGULAR POSITION USING ONLINE SYSTEM DESIGNED WITH LABVIEW

Four turns absolute angle value is calculated from the data send from the PIC16F877A microcontroller using LabVIEW software is discussed here

A. Analysis Of Accrued Data From Two Sensors

Data acquired using microcontroller interface to PC with LabVIEW is used for analysis of result obtained from four rotations of hub gear wheel, which is connected to cog wheels with magnets and sensors. A stepper motor is used to rotate the hub gear wheel uniformly to measure the angle data for analysis. The accrued data from both iGMR is plotted in graph as shown in fig 2 (a). This graph shows the relationship between two values of output from iGMR₁ and iGMR₂ after complete four turn of hub gear wheel (1440°). In x axis hub wheel rotation angle and in y axis measured values from both iGMR sensors is plotted. From this it is clear that the difference between two sensor values varies linearly with respect to other.

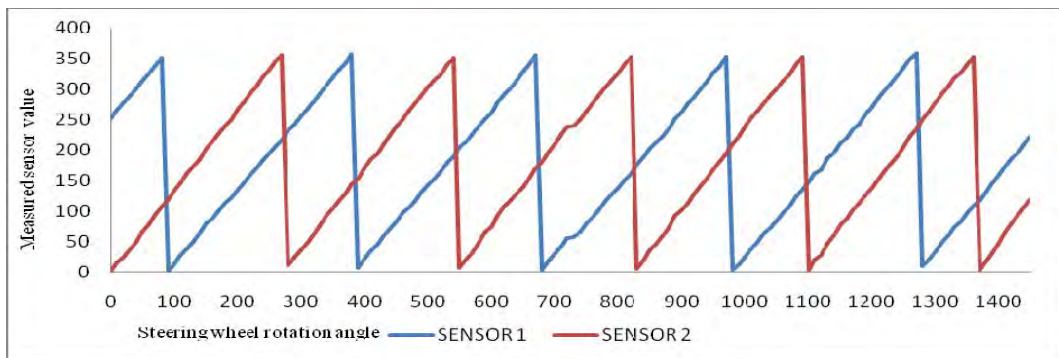

Fig 2. (a) Acquired data from both iGMR sensors for same angular rotation of hub gear wheel

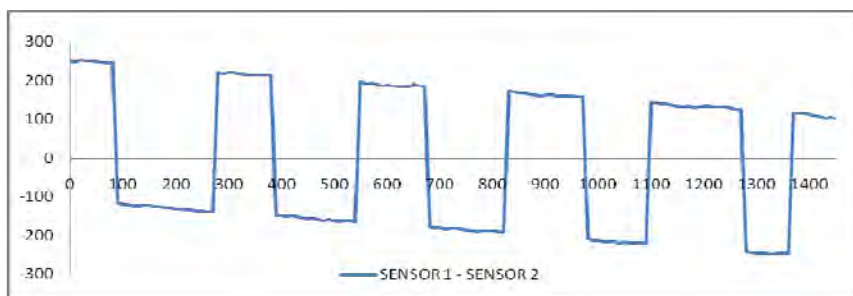

Fig 2. (a) Difference plotted between iGMR₁ angle iGMR₂.

iGMR₁ angle value is subtracted with iGMR₂ angle value to obtain the variation in two measured values and plotted a graph as shown in fig 2 (b). It shows that the difference between the two sensors decreasing linearly while increasing the number of turns or degree of rotation. From this it is concluded that if the difference between two sensor values are measured then it is possible to find the number of turns of the steering wheel using a lookup table. Using equation (1) calculated the angle of steering wheel, the output after four rotations is shown in Fig 3 (a). It is linearly increasing from 0° to 1440°.

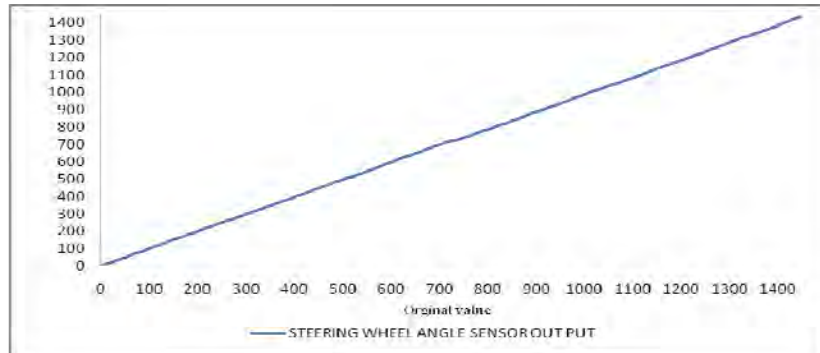

Fig 3 (a) angular rotation with respect to sensor angle value



Fig 3 (b) LabVIEW front panel which shows the angle value with steering wheel rotation

B. Implementation Steering Wheel Angle Sensor

The sensor is implemented on an actual steering wheel as shown in Fig 4. Hub wheel is fixed to the steering column and cogwheels are attached to it. When the steering wheel rotates, the hub wheel attached to it internally rotates its cogwheels with magnets at the center and the relative position of the cogwheels are obtained. From this the steering wheel angle is measured. The sensor requires no power supply when the engine is switched off. In spite of getting a power supply during the engine switch off, the sensor marks the current steering angle when turned on.



Fig 4 Implementation of sensor system in car steering

The advantage of the system is not limited to the increase in measurement range, the system gives a fixed range for measuring angle. The interaction exists between two cog wheels thereby providing a limited number of settings for steering angle. If the measured values go beyond the available range the interface protocol is invalid.

C. Error Analysis

The implementation of sensor system is shown in Fig.4. The error graph for steering wheel angle sensor is shown in Fig.5. In this graph x axis represents the original steering wheel angle ϕ and y axis represents the calculated error. The error for this system reaches 4° in some locations. The reason for error is permanent magnet alignment is not correct due to assembly error and effect of gear precision.

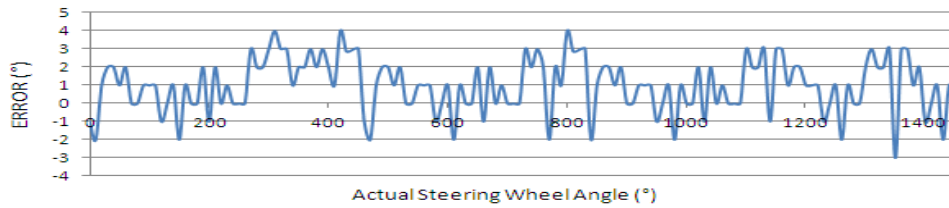

Fig. 5 Experimental error for steering wheel angle sensor

VI. CONCLUSION

In this paper, we described the design and implementation of a steering wheel angle sensor system based on iGMR. This system gives a flexible design for absolute four-turn steering wheel angle measurement. The error can be minimized to less than 1.5° using accurate mechanical assembly. Using this principle, it becomes feasible to cover a measurement range of four-turns steering-wheel rotations without the need to use a revolution counter or register. The steering-wheel angle is produced in the form of an absolute angle across the entire steering-column rotation range and no quiescent current required to store steering angle data. This flexible design allows wide scope of applications.

REFERENCES

- [1] Infineon, "EPS with GMR-Based Angular and Linear Hall Sensor," Germany: Infineon Technologies, 2008.
- [2] Elmar Dilger Matthias Gulbins, Thomas Ohnesorge, Bernd Straube: On a Redundant Diversified Steering Angle Sensor. Robert Bosch GmbH, 2003.
- [3] William Kimberly: Automotive Electrics and Automotive Electronics systems and components 4th edition Robert Bosch GmbH, Professional Engineering publishing, January 2004 .
- [4] TLE5010 GMR Based Angular Sensor: Infineon Preliminary Data Sheet, V 0.9, May 2007.