

CHPS IN CLOUD COMPUTING ENVIRONMENT

K.L.Giridas^{#1}, A.Shajin Nargunam^{#2}

[#]Department of Computer Science and Engineering,
Noorul Islam University, Kumaracoil,
Tamilnadu-6129180, India.

¹giridas@yahoo.com

²shajin@niuniv.com

Abstract -Workflow have been utilized to characterize a various form of applications concerning high processing and storage space demands. So, to make the cloud computing environment more eco-friendly, our research project was aiming in reducing E-waste accumulated by computers. In a hybrid cloud, the user has flexibility offered by public cloud resources that can be combined to the private resources pool as required. Our previous work described the process of combining the low range and mid range processors with the high end processor to make the IT environment without e-waste. Then we focused on the allocation of resources in an optimal manner with respect to bandwidth and processors' ability. In this paper we deal with presenting (CHPS) Compatibility of Hybrid processor scheduler in green IT cloud computing environment. CHPS decides which resources should be chartered from the public cloud and combined to the private cloud to offer adequate processing power to perform a workflow inside a specified execution time. We present widespread experimental and simulation results which illustrate that CHPS can decrease costs as attaining the recognized preferred execution time.

Keywords - Hybrid processor schedule, cloud computing, Green IT, CHPS.

I. INTRODUCTION

Cloud computing is currently being utilized to distribute on demand storage and dealing out power. This situation permits the letting of resources to progress the nearby offered computational capability, providing novel computing resources when needed. In a cloud, the user admits working out resources as common utilities that can be chartered and unrestricted. The major benefits to the cloud users is the prevention of straight speculation, the lesser of their working cost, the preservation cost diminution, and the scalability offered on demand. These cloud features present flexibility to the user's computing situation, being capable to adjust the computer system to the user desires.

In the cloud computing standard, particulars are distracted from the users. They do not want information of, knowledge in, or organize over the knowledge communications about the cloud they are employing. It classically engages the stipulation of vigorously scalable and regularly virtualized resources as an examination over the Internet. The cloud computing uniqueness is on demand self-service, omnipresent network admittance, self-governing resource location (consistency), rapid flexibility (scalability), and disburses per use. The cloud computing permits the exercise of Service Oriented Computing (SOC) standards, consenting users to institute links among services, organizing them as workflows as a substitute of constructing only conventional applications using programming languages.

Cloud contributors present storage resources, and platforms for software expansion and implementation, in addition to software interfaces available all through the network. Three representations of cloud services are normally accessible: Infrastructure as a Service (IaaS), Platform as a Service (PaaS), or Software as a Service (SaaS). In SaaS, the clients exercise applications but cannot organize the host situation. Google Apps and Salesforce.com are instances of this model. In PaaS, the proposal is naturally an appliance structure and clients exercise a hosting atmosphere for their applications. Examples of PaaS are the Google App Engine and Amazon Web Services. In IaaS, the clients exploit computing resources for instance processing power and storage space and they can also manage the situation and the consumption of applications.

In terms of resources accessibility, we can categorize IaaS clouds in three various types:

- a.)Public clouds: Resource providers' present computing resources as services in a pay-per-use basis, letting the exercise of machines to the user through the demanded time.
- b.)Private clouds or domestic clouds: Clouds with resources that can be admitted and used by persons within an organization, containing likeness with data farms or private grids.
- c.)Hybrid clouds: Bring collectively public and private clouds, ensuing in a permutation of control over performance and safety with flexibility.

The on-demand calculation, enclosed by the cloud, permits the exercise of private systems (computers, clusters, and grids), combine the cloud resources as users have to. Nevertheless, this hybrid approach consequences in a system with novel demands, particularly in resource organization.

In [1], the author presents HCOC: The Hybrid Cloud Optimized Cost scheduling algorithm for cloud computing environment. HCOC is an algorithm to expedite the implementation of workflows following a preferred execution time, but also dipping costs when contrast to the greedy approach. But HCOC failed to contract with numerous workflows is a significant issue. In addition that, allowing for the possible incidence of exterior load in private resources could progress the scheduling decisions.

In this paper we deal with the problem of identifying the users' desired resources and the time and task which they want to perform by adapting CHPS: Compatibility of Hybrid processor scheduler in green IT cloud computing environment. CHPS decides which resources should be chartered from the public cloud and combined to the private cloud to offer adequate processing power to perform a workflow inside a specified execution time.

II. LITERATURE REVIEW

The cloud computing service representation engages the stipulation, by a service supplier, of huge pools of elevated performance calculating resources and high-capacity storage space devices that are common amongst end users as vital. There are several cloud repair models, but normally, end users promising to the service contain their data hosted by the service, and have calculating resources owed on demand from the group. Workflows have been utilized to signify a diversity of applications connecting elevated processing and storage space demands. As a resolution to deliver this obligation, the cloud computing standard [1] has appeared as an on-demand resources supplier.

In [2], proposed that the cluster encloses collection of trusted nodes. A general node among two clusters is chosen as Process Migration Server which we will currently refer as Process Management Server (PMS). A forecasting approach is divided into two parts. The first part contracts with active run queue organization by properly weighting methods to main memory from process pool [3]. The processors' immigration is admitted with Lightweight Process Migration and Memory Prefetching in Open MOSIX [4] and the task preparation is also being completed with repetition bounded processors [5].

Workflow arrangement in combination with service composition in grids is discussed in [6]. In [7], Bossche et. al contract with the development of self-determining tasks on hybrid clouds. They presented a binary integer course to choose which cloud supplier to decide when outsourcing a task that cannot be presently performed in the private cloud. In [8], it discussed a problem of identifying the cloud processors' tasks by presenting HCOC: The Hybrid Cloud Optimized Cost scheduling algorithm. To improve an efficient cloud computing authentication scheme, Cloud Computing Background Key Exchange [9] is used. The cloud computing services are examined and progressed with the decision of processing tasks [10].

Since cloud computing services are uncomplicated to use, and can reduce both skill costs and environmental loads [11]. Fairness should be pursued while captivating abundant types of resource into reflection. There are numerous papers that discuss algorithms for achieving fairness for cases where a shared resource distribution is not measured [12]. To give cloud computing services practically, it is important to optimize resource allocation under the declaration that the necessary fair resource [13] can be taken from a widespread resource group. Only time is calculated and scheduled for each incoming task, and random selection of resources is done [14].

III. PROPOSED COMPATIBILITY OF HYBRID PROCESS SCHEDULER (CHPS)

The proposal work presents compatibility of hybrid processor scheduler to make the cloud computing environment more eco-friendly. The green IT environment is achieved by adapting the users' time, task and resource optimization with respect to energy level consumption.

The proposed Compatibility of Hybrid processor scheduler in green IT cloud computing environment is worked under three different phases. The first phase describes the process of identifying the pool of processors and assignment of those processor based on time and task schedules. The second phase described the process of allocating the resources to a set of processors in an optimal manner. The third phase describes the Compatibility of Hybrid Process Scheduler in Cloud Computing with old, mid range and modern processors suiting to various operating system environments and application needs. The architecture diagram of the proposed Compatibility of Hybrid processor scheduler in green IT cloud computing environment is shown in fig 1.

The first phase describes the process of combining the low range and mid range processors with the high end processor to make the Information technology environment as Green IT without evaluating any e-wastes. This is done based on cloud interface. The cloud interface process consists of task schedule and process allocation. It will assign the appropriate tasks to the processor which is free and continued the task to be performed.

The second phase describes the process of optimal resource allocation method in terms of bandwidth and processing ability. The third phase described the process of identifying the compatibility of the process scheduler based on the users' task, time and processors' ability.

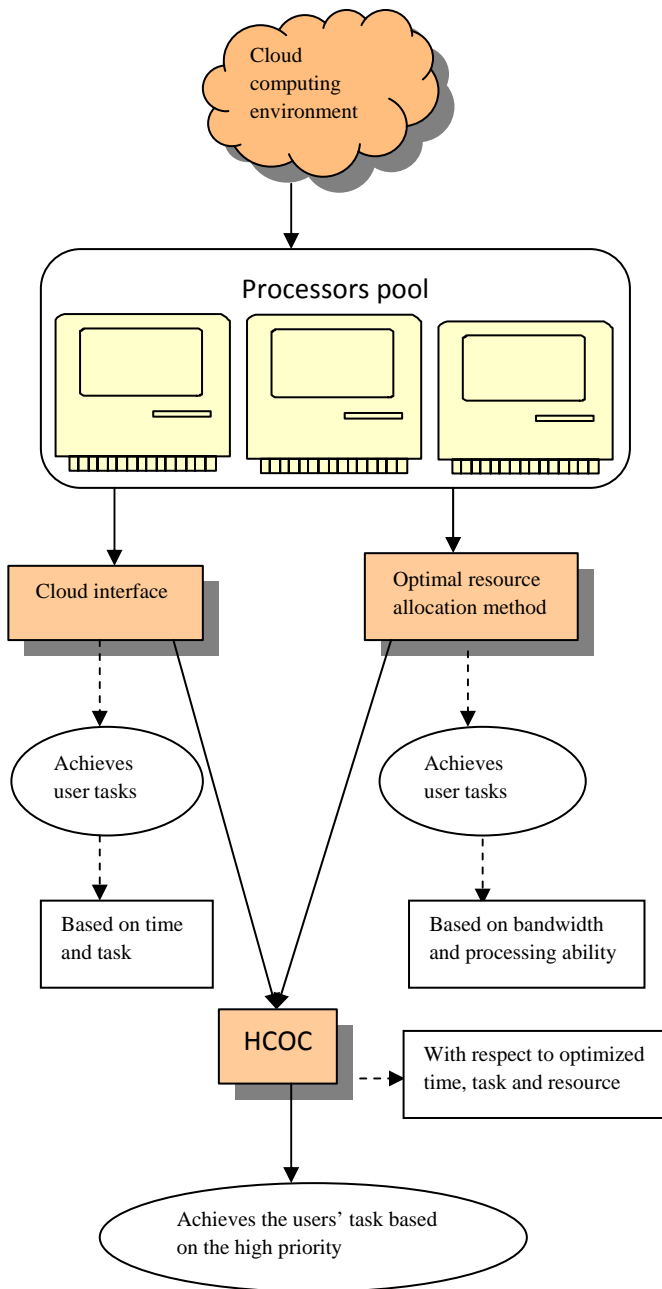

Fig 1: Architecture diagram of the proposed CHPS

A. Hybrid cloud infrastructure and Cloud Interface.

In a hybrid system collection of a private cloud with the opportunity of admitting a public cloud computing communications, the workflow organization must provide the necessities in various levels. First, it must afford services to the user to build submissions without the need of choosing or indicating the localization of the computational resources to be used. Within the private cloud margin, the workflow executive must identify the best resources obtainable and, when required, it must build the active exploitation of services in these resources. Alternatively, within the public cloud margin, the hybrid cloud infrastructure must be capable to cooperate with the public cloud interfaces to acquire computational resources. Subsequently, it must be capable to arrange these resources consistent with workflow necessities, by building the active exploitation of services in the resources within the public cloud.

The main process on cloud interface is to schedule the tasks according to the processing time (t). If the user wants to perform a new task in the same environment, the user should enter into the environment, by obtaining the task id, name and the number of instructions executed per second and the tasks required time to complete the task. Then it involves displaying the list of tasks and processes it already has. The group tasks include number of tasks it has, the processing time of the group with a required time to perform the tasks. The ITTPS architecture described in the previous work schedule the number of tasks based on the task entry into the cloud computing environment. Depends on the required time of the users' tasks, the ITTPS architecture determines the processor to allocate like whether to assign old, mid and modern range processor. If the required time of the task is less than the low range processors' processing time, then it will assign to the low range processor for processing without throwing the old range processor to e-waste. If the tasks required time is higher than the mid range processors' processing time, then the task will assign to the high range processor based on its CPU processing time. Thus the tasks are assigned to the appropriate processors type efficiently and reduce the e-wastes by carrying over both the mid and low range processor for processing the users' task in a cloud environment based on the processing time and task of the users.

B.) Optimal resource allocation method and CHPS:

The resource allotment in a cloud computing environment can be represented by assigning the requisite quantity of numerous types of resource concurrently from a widespread resource pool for a definite stage of time for every request. The requisite quantity of resource and the interlude of time in which it is utilized are not predetermined. They can differ significantly from user to user and from service to service. The objective of the optimal resource allocation technique is to exploit the number of requests to which both resource processing capability and bandwidth are maintained well. As the amount of requisite resource processing capability does not usually have a rigid association with that of requisite bandwidth, the finest resource allocation cannot be attained.

The compatibility of Hybrid Process Scheduler is done in Cloud Computing with old, mid range and modern processors suiting to various operating system environments and application needs. The hybrid process scheduler is used to assign the appropriate tasks to the resource pool with respect to optimal resource, time and task schedulers. Based on the resource and time schedule, the process of assigning the users' task to the appropriate processor pool is to be done with respect to the energy level. Then initial step in CHPS is to make an initial schedule of users' tasks to the appropriate processor pools based on the terms described below [8],

Computation cost:

$$w_{i,r} = \frac{\text{instructions}}{p_r} \dots \text{(eqn.1)}$$

$w_{i,r}$ signifies the calculation cost (execution time) of the node i in the resource r , and p_r is the processing capability of resource r in instructions per second. $\text{suc}(t_i)$ is the set of immediate successors of users' tasks t_i . $\text{pred}(t_i)$ is the set of immediate predecessors of users' tasks t_i .

Priority:

$$P_i = w_{i,r}, \text{suc}(t_i) = \phi$$

$$w_{i,r} + \max_{t_j \in \text{suc}(t_i)} (c_{i,j} + P_j), \text{otherwise} \dots \text{(eqn. 2)}$$

P_i is the priority level of tasks i at a given time second through the scheduling process.

Earliest start time:

$$\text{EST}(n_i, r_k) = \text{Time}(r_k), \text{if } i = 1$$

$$\text{Max}\{\text{Time}(r_k), \text{starting time}\} \text{ Otherwise } \dots \text{(eqn. 3)}$$

$\text{EST}(n_i, r_k)$ represents the earliest start time possible for task i in resource k at a given scheduling instant. $\text{Time}(r_k)$ is the time when resource k is available to execute tasks i .

Estimated Finish time:

$$\text{EFT}(n_i, r_k) = \text{EST}(n_i, r_k) + w_{i,k} \dots \text{(eqn. 4)}$$

$\text{EFT}(n_i, r_k)$ represents the estimated finish time of task i in resource k .

After identifying the EST and EFT of the users' tasks, the energy level of the task is observed for the resources based on its behavior. Choose the best resource with respect to energy level and assign the users' tasks to that processor in an optimal manner.

The two major steps of the CHPS algorithm (fig.2) are the collection of tasks to reorganize and the collection of resources from the open cloud to arrange the hybrid cloud. As the previous chooses which tasks can include their execution time condensed by using more prevailing resources from the public cloud, the final establishes the performance and costs concerned in the novel schedule. Through the process of identifying the

EST and EFT of the users' tasks, resources are assigned efficiently based on the highest priority given to it with respect to energy level.

The CHPS algorithm is based on the following general steps:

Step 1: Initial schedule: schedule the users' tasks in the private cloud R;
 Step 2: While the processing period of task is larger than the deadline:
 Step 2.1: Choose tasks to reorganize; // ITTPS
 Step 2.2: Choose resources from the public clouds to create the hybrid cloud H with respect to energy level
 // CHPS

Fig 2. Algorithm of CHPS

IV. EXPERIMENTAL EVALUATION

The proposed Compatibility of Hybrid processor scheduler in green IT cloud computing environment is implemented in Java using cloudsim software. The proposed CHPS used old range, mid range and high end processors for experimental evaluation. The old range processors includes 286, 386, Pentium, the mid range processors includes Pentium pro, Pentium III, Pentium IV, the high end processors be core2, core i7. These types of processors pools are integrated to analyze the performance of the proposed CHPS for green cloud computing based on time, task, and resource optimization with respect to energy. The number of tasks assigned to the processor is based on the capability of the processor in the resource pool measured in terms of CPU cycles, bandwidth, and data rate with respect to the optimized energy resources. The proposed CHPS first identifies the tasks schedule, resource/processor capability. An optimized resource allocation takes place under the assumption that the required resource can be taken from a shared resource pool. In addition, to be able to provide processing ability and storage capacity, it is necessary to allocate bandwidth to access them at the same time. Operations can be assigned to the pool of old range and mid range processors with high end processors. The proposed CHPS for cloud computing infrastructure is measured in terms of:

- i.) Execution time
- ii.) Communication overhead
- iii.) I/O operation efficiency
- iv.) Execution cost

V. RESULTS AND DISCUSSION

In this work, we have seen how a pool of processors can be allocated to users' tasks based on optimal time, task, and resource utilization technique with respect to energy level to capture the performance of cloud computing process in Green IT to other systems written in mainstream languages such as Java. We run independent tests with several number of resources task with a constant number of tasks sent by each users. The entire process of the proposed CHPS for green cloud computing is explained in section 3 briefly. Compared to the previous work integrated time and task based process schedule and resource optimization technique, the proposed CHPS provides an efficient mechanism to reduce the e-waste in the way of assigning the users' task schedule and also concerned about the resource wastage. The proposed CHPS architecture provides better results in terms of utilization of resource for eradicating the e-waste by accumulating minimum amount of energy. The below table and graph shows the performance of the proposed CHPS for green cloud computing compared with an existing integrated time and task based process schedule and resource optimization technique.

TABLE I.
NO. OF TASKS VS. EXECUTION TIME

No. of tasks	Execution time (secs)		
	Proposed CHPS	ORAT	ITTPS
5	2.3	5.6	6.8
10	4.6	7.2	8.7
15	6.2	9.6	7.9
20	7.9	11.1	10.9
25	8.6	13.2	14.2

The above table (table 1) describes the time taken to perform the task based on the number of tasks arrives into the network environment. The outcome of the proposed Compatibility of Hybrid processor scheduler in green IT cloud computing environment is compared with the previous ORAT and ITTPS techniques.

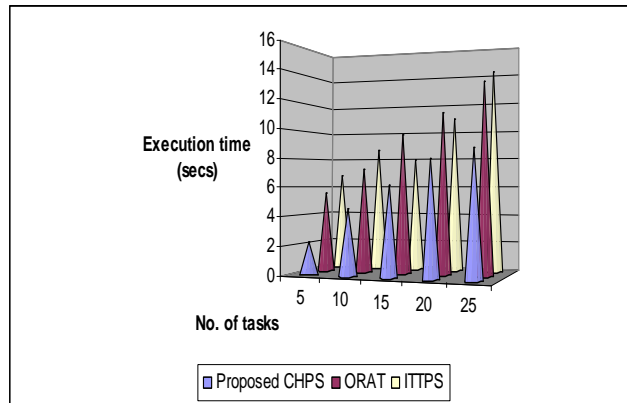

Fig.3: No. of tasks Vs. Execution time

Fig.3 describes the execution time taken to perform the task based on the number of tasks present in the network environment. The execution time is measured in terms of how long the processor in the processor pool takes to perform the task. Based on the number of tasks, the execution time is computed. In the proposed CHOS, the tasks are assigned to the processor which has the highest priority of doing the task based on time and task schedules. Since the processor has been chosen based on the resource optimization with respect to the energy, the consumption of time to execute the task is low. Compared to the previous work ORAT and ITTPS which concerns only about the time and resource individually, the proposed CHPS concerned both the time and resource to process the users' tasks. The consumption of time to execute the task in the proposed CHPS is low and the variance is 50-60% low in the proposed CHPS.

TABLE II.
NO. OF USERS VS. COMMUNICATION OVERHEAD

No. of users	Communication overhead		
	Proposed CHPS	ORAT	ITTPS
10	4	7	10
20	9	10	18
30	11	16	15
40	12	13	24
50	14	20	26

The above table (table 2) describes the chance of communication overhead raise based on the number of users participate in it. The outcome is compared with the previous ORAT and ITTPS techniques.

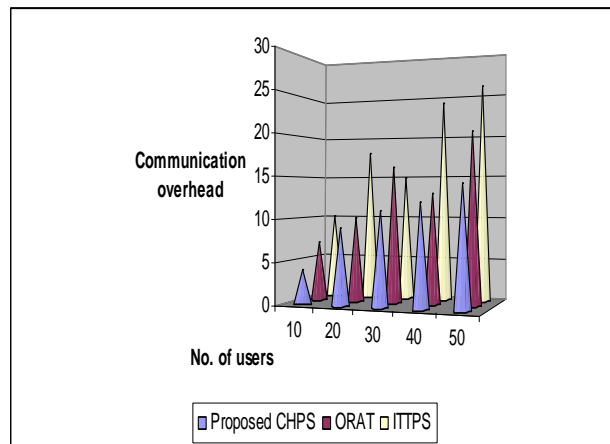

Fig.4: No. of Users vs. Communication overhead

Fig.4 describes the communication overhead raise based on the number of users participate in it. The communication overhead is measured in terms of loss of tasks met when more number of requests arrived into the environment. Since the proposed CHPS followed the resource with time optimization technique respect to the energy, the users' task is assigned to the processor depends upon the energy level it needs. The energy level is based on the time and task of the users' task consumes. Compared to the previous work ORAT and ITTPS which concerns only about the time and resource individually, the proposed CHPS concerned both the time and resource to process the users' tasks. The communication overhead in the proposed CHPS is low and the variance is 50-60% low in the proposed CHPS.

The above table (table 3) describes the I/O communication efficiency based on the number of tasks participate in it. The outcome of the proposed Compatibility of Hybrid processor scheduler in green IT cloud computing environment is compared with the previous ORAT and ITTPS techniques.

TABLE III.
NO. OF TASKS VS. I/O OPERATION EFFICIENCY

No. of tasks	I/O operation efficiency		
	Proposed CHPS	ORAT	ITTPS
10	25	12	9
20	36	30	11
30	50	24	16
40	63	33	13
50	75	40	20

Fig.5 describes the efficiency of I/O operation carried over by the processor based on the number of tasks assigned in it. Based on the number of tasks, the efficiency of input/output operation is measured. In the proposed CHPS, the input/output operation is carried over efficiently by optimizing the both time and resource. Compared to an existing ORAT and ITTPS, the proposed CHPS provides an efficient input/output operation by assigning the users' tasks to the processor it needs.

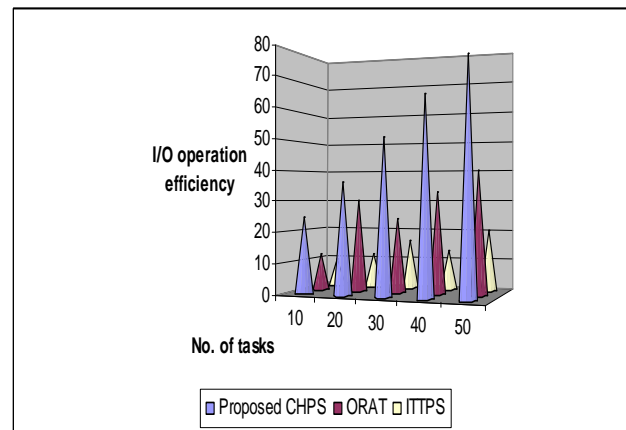

Fig.5: No. of Tasks vs. I/O operation efficiency

The above table (table 4) describes the execution cost based on the execution time of the tasks participate in it. The outcome of the proposed Compatibility of Hybrid processor scheduler in green IT cloud computing environment is compared with the existing HCOC.

Table IV.
Execution time vs. Execution cost

Desired execution time (deadline)	Execution cost	
	Proposed CHPS	Existing HCOC
50	100	250
100	230	340
150	290	460
200	320	540
250	390	600

Fig.6 describes the process of determining the execution cost to perform the users' tasks based on the desired execution time. Existing HCOC presented a process of assigning the workflow in a simple manner i.e., it assigns the users' workflow to the processor based on the priority scheme alone. But in the proposed CHPS, the process of assigning the users' tasks to the resource pool is done in an optimal manner with respect to the energy. Based on the energy level of the resources in the resource pool, the users' tasks are assigned. Before that, an optimal time and resource is selected then assigned to it. Compared to an existing HCOC, the proposed CHPS provides a less execution cost, since it chose the resource based on the energy level of the resources and the variance is 50-70% low in the proposed CHPS.

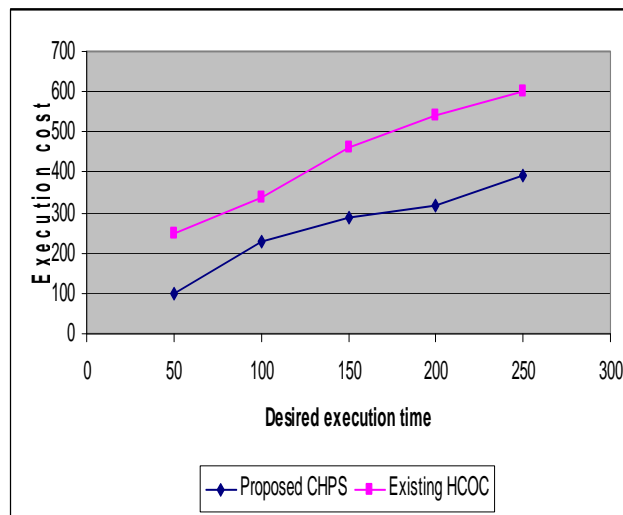

Fig.6: Execution time vs. Execution cost

At last, it is observed that the proposed CHPS for green cloud computing outperforms well by adapting the optimal resource and time allocation method. The proposed CHPS for cloud computing assigned the processors to the tasks based on its Resource Usage (bandwidth, CPU cycles, I/O operation, Energy, and data transfer rate). Based on the resource capability, the task has been assigned to the resource, so it consumes less time to process and execute the task and it utilize all the resources without any processors waste. Compatibility of Hybrid Process Scheduler in Cloud Computing with old, mid range and modern processors suiting to various operating system environments and application needs.

VI. CONCLUSION

In this paper we present CHPS: Compatibility of Hybrid processor scheduler to make IT as green IT in cloud computing environment. CHPS is an algorithm to accelerate the execution of users' tasks obeying a preferred execution time, but also dropping costs when compared to the previous works ORAT and ITTPS. The proposed CHPS for cloud computing assigned the processors to the tasks based on its Resource Usage (bandwidth, CPU cycles, I/O operation, Energy, and data transfer rate). Based on the resource capability, the task has been assigned to the resource, so it consumes less execution time and improves high communication efficiency. Compatibility of Hybrid Process Scheduler in Cloud Computing is efficiently designed with old, mid range and modern processors suiting to various operating system environments and application needs. An extensive evaluation carried out in this work presents adequate data to sustain the conclusion that the CHPS algorithm can present proficient resource scheduling in a hybrid cloud circumstances.

REFERENCES

- [1] Shakti Mishra, Dharmender Singh.Kushwaha et. Al., 2010. “An Efficient Job Scheduling Technique in Trusted Clusters for Load Balancing”, The First International Conference on Cloud Computing, GRIDs, and Virtualization
- [2] Shakti Mishra, D.S.Kushwaha, and A.K.Misra, Aug.2009. “Jingle- Mingle: A Hybrid Reliable Load Balancing Approach for a Trusted Distributed Environment”, 5th IEEE International Joint Conference on INC, IMS & IDC, NCM, pp. 117-122.
- [3] Siddha S., Pallipadi V., Mallick A., 2007. “Process Scheduling Challenges in Multicore Processors”, Intel Technology Journal, Vol. 11 , Issue 04, pp. 361-369.
- [4] Ho, R.S.C., Cho-Li Wang, and Lau, F.C., 2008. “Lightweight Process Migration and Memory Prefetching in Open MOSIX”, IEEE International Symposium on Parallel and Distributed Processing IPDPS, pp. 1-12.
- [5] S. Pasham and W. Lin, 2005. “Efficient task scheduling with duplication of bounded number of processors”, 11th International Conference on Parallel and Distributed Systems (ICPADS'05), vol. 1, pp. 543-549.
- [6] Bittencourt, L.F., Senna, C.R., Madeira, 2010. “E.R.M.:Scheduling service workflows for cost optimization in hybrid clouds”, 6th International Conference on Network and Service Management (CNSM). Toronto,Canada.
- [7] Van den Bossche, R., Vanmechelen, K., Broeckhove, J., 2010. “Cost-Optimal Scheduling in Hybrid IaaS Clouds for Deadline Constrained Workloads”, 3rd International Conference on Cloud Computing, pp. 228–235.
- [8] Luiz Fernando Bittencourt et. Al., 2011. “HCOC: A Cost Optimization Algorithm for Workflow Scheduling in Hybrid Clouds”, Journal of Internet Services and Applications, v.2, no.3, pp.207(21) (ISSN: 1867-4828)
- [9] Chang Liu et. Al., 2012. “CCBKE — Session key negotiation for fast and secure scheduling of scientific applications in cloud computing”, Future Generation Computer Systems.
- [10] A. Iosup, S. Ostermann, et. Al., 2011, “Performance Analysis of Cloud Computing Services for Many-Tasks Scientific Computing, Parallel and Distributed Systems”, IEEE Transactions, pp.931-945.
- [11] P.Mell and T.Grance, July 2009. “Effectively and securely Using the Cloud Computing Paradigm”, NIST, Information TechnologyLab.
- [12] P.Yue, Z.Liu and Z.Zhang, April 2006. “Fair bandwidth allocation for responsive and unresponsive flows using approximate fairness dropping scheme”, IEICE Trans. Commun., Vol.E89-B, No.4.
- [13] K.Hatakeyama, S.Tsumura and S.Kuribayashi, Oct.2008. “Fair joint multiple resource allocation method in all-IP networks”, Proc. of 14th Asia-Pacific Conference on Communications (APCC2008), 15-PM1-F-3.
- [14] K.L.Giridas, A.Shajin Nargunam, A Novel Architecture for Hybrid Processor Pool Model using ITTPS Scheme, International Journal of Computer Applications, vol.49-No.5, July 2012.